

Application

The AV-390 through AV-396 linkages are used to field assemble Schneider Electric gear train actuators to VB-7XXX series or VB-9XXX series valve bodies.

- AV-391 and AV-393 are used with current 1/2" to 2" VB-7X1X and obsolete 1/2" to 1-1/4" VB-9X1X valve bodies.
- AV-392 and AV-394 are used with obsolete 1-1/2" and 2" VB-9X1X valve bodies.
- AV-395 and AV-396 are used with current 2-1/2" to 4" VB-9X1X valve bodies.

Features

- Die cast aluminum mounting bracket.
- Valve position indication provided as standard.

Applicable Literature

- Environmental Controls Cross-Reference Guide, F-23638
- Environmental Controls Reference Manual, F-21683
- Environmental Controls Application Manual, F-21335
- Pneumatic Products Catalog, F-27383
- EN-205 Water System Guidelines, F-26080

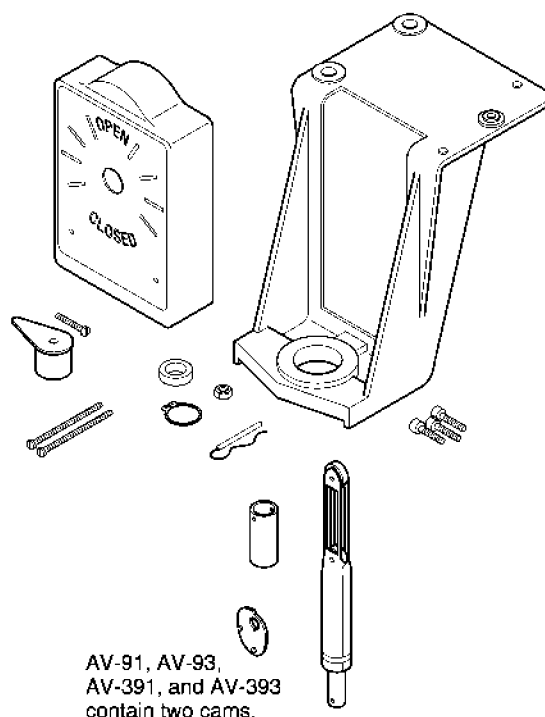

SPECIFICATIONS

Table-1 Model Chart.

Valve Linkage Model Number	Description	Stem Force (lb.)
AV-390	Cam, Plunger, and Stem Extension Kit Req. AV-91, AV-92, AV-93, AV-94	—
AV-391	Complete Linkages	150
AV-392		300
AV-393		150
AV-394		300
AV-395		150
AV-396		300

Temperature Restrictions

Verify that the fluid temperature of the media in the valve versus the ambient temperature at the actuator does not exceed the ratings shown in Table-1.

Table-2 Restrictions on Maximum Ambient Temperature for Actuators.

Maximum Temperature of Media in the Valve (Check Rating of Valve) °F (°C)	Maximum Ambient for Actuator °F (°C)
260 (126)	136 (57)
281 (138)	125 (52)
300 to 366 (149 to 185)	100 (37)

Close-off Pressure Rating

Close-off pressure ratings are listed in Table-2 and Table-3. Check the appropriate table to verify that the selected valve, valve linkage, and actuator provide adequate close-off pressure for your application.

Required Components

The actuator, valve, and valve linkage should be purchased separately. See Table-2 and Table-3 for selections.

INSTALLATION

Inspection

Inspect the package for damage. If damaged, notify the appropriate carrier immediately. If undamaged, open the package and inspect the device for obvious damage. Return damaged products.

Requirements

- Tools (not provided):
 - Appropriate wrenches for stem extensions, lock nuts, packing nuts, and brackets
 - Appropriate screwdriver for actuator mounting screws
 - TOOL-37, 1-5/8" open-ended wrench with a maximum thickness of 3/16"
- Training: Installer must be a qualified, experienced technician

Caution:

- Avoid locations where excessive moisture, corrosive fumes, or vibration is present.
- Install all two-way valves so that they close against the flow. An arrow on the valve body or a tag indicates the proper flow direction.
- Always install three-way mixing valves with two inlets and one outlet.
- Always install three-way diverting valves with one inlet and two outlets.
- The actuators can be mounted in any position above the centerline of the valve body. For steam applications where the ambient temperature approaches the limit of the actuator, the valve stem should be mounted 45° from vertical. When selecting a location, allow sufficient room for accessories and for service of the product.

Table-3 Linkage Selection and Valve Close-Off Pressure Ratings for VB-7XXX and VB-9X1X Valve Bodies.

					TYPICAL ACTUATOR PART NUMBERS						
					Normally Closed (Stem Down) MA-318, MA-318-500 MA-416, MA-416-500 MA-418, MA-418-500 MA-419, MA-419-500 MP-361, MP-367 MP-461-600 MP-465, MP5-461	Normally Open (Stem Up) MA-318, MA-318-500 MA-416, MA-416-500 MA-418, MA-418-500 MA-419, MA-419-500 MP-371, MP-377 MP-471-600, MP-475, MP5-471	MP-421 MP-422 MP-2150-500 MP5-2151-500	No Normal Position MC-351, MC-421, MC-431 MC-4211, MC-4311, MC5-4311 MP-381, MP5-381, MP-382 MP-387, MP-451, MP-452 MP-481-600 MP-485, MP-486 MP-4851, MP5-4851			
Minimum Torque/Travel Required					50 lb.-in., 180°			100 lb.-in., 180°			
Linkage for 1/2" to 2" Valves					AV-391 (AV-390 & AV-91)			AV-393 (AV-390 & AV-93)			
Linkage for 2-1/2" to 4" Valves					AV-395			AV-396			
VALVE BODY INFORMATION					CLOSE-OFF PRESSURE (psi) ^a						
Valve Body Part Number	Description	P Code	Size	Cv							
VB-7211-0-3-P	2-Way NPT	1	1/2"	0.4	250	250					
		2		1.3							
		3		2.2							
		4		5.0							
		5	3/4"	5.5							
		6		8.5							
		7	1"	14							
		8		16							
		9	1-1/4"	22				90	200		
VB-7211-0-4-P	2-Way NPT	1	1/2"	0.4	250	250					
		2		1.3							
		3		2.2							
		4		4.4							
		5	3/4"	5.5							
		6		7.5							
		7	1"	10							
		8		14							
		9	1-1/4"	20				90	200		
VB-7213-0-4-P VB-7214-0-4-P VB-7215-0-4-P VB-7253-0-4-P VB-7273-0-4-P	2-Way	1	1/2"	0.4	250	250					
		2		1.3							
		3		2.2							
		4		4.4							
		5	3/4"	5.5							
		6		7.5							
		7	1"	10							
		8		14							
		9	1-1/4"	20				90	200		
		10	1-1/2"	28				65	140		
		11	2"	40				35	80		
		VB-9213-0-4-P VB-9215-0-4-P		12				2-1/2"	65	20	50
				13				3"	85	12	34
VB-9213-0-5-P	2-Way 125 lb. Flanged	12	2-1/2"	56	20	50					
		13	3"	85	12	34					
		14	4"	145	6	17					
VB-7313-0-4-P VB-7314-0-4-P VB-7315-0-4-P	3-Way	2	1/2"	2.2	250	250					
		4		4.4							
		6	3/4"	7.5				220			
		8	1"	14				150	SU: 150 SD: 140		
		9	1-1/4"	20				100	SU: 100 SD: 95		
		10	1-1/2"	28				60	SU: 80 SD: 75		
		11	2"	41				33	SU: 200 SD: 190		
		12	2-1/2"	67				20	50		
VB-9313-0-4-P VB-9315-0-4-P		13	3"	91	12	34					
		14	4"	170	6	17					
VB-9313-0-5-P	3-Way 125 lb. Flanged	12	2-1/2"	74	20	50					
		13	3"	101	12	34					
		14	4"	170	6	17					

^a kPa = psi x 6.895

Table-4 Linkage Selection and Valve Close-off Pressure Ratings for Obsolete VB-9XXX Valve Bodies.

					TYPICAL ACTUATOR PART NUMBERS						
					Normally Closed (Stem Down) MA-318, MA-318-500 MA-416, MA-416-500 MA-418, MA-418-500 MA-419, MA-419-500 MP-361, MP-367 MP-461-600 MP-465, MP5-4651	Normally Open (Stem Up) MA-318, MA-318-500 MA-416, MA-416-500 MA-418, MA-418-500 MA-419, MA-419-500 MP-371, MP-377 MP-471-600 MP-475, MP5-4751	No Normal Position MP-421 MP-422 MP-2150-500 MP5-2151-500	No Normal Position MC-351, MC-421, MC-431 MC-4211, MC-4311, MC5-4311, MP-381, MP-382, MP-387 MP-445-304, MP-451, MP-452, MP-481-600, MP-485, MP-486, MP-4851, MP5-4851			
Minimum Torque/Travel Required					50 lb.-in., 180°			100 lb.-in., 180°			
Linkage for 1/2" to 1-1/4" Valves					AV-391 (AV-390 & AV-91)			AV-393 (AV-390 & AV-93)			
Linkage for 1-1/2" & 2" Valves					AV-392 (AV-390 & AV-92)			AV-394 (AV-390 & AV-94)			
VALVE BODY INFORMATION					CLOSE-OFF PRESSURE (psi) ^a						
Valve Body Part Number	Description	P Code	Size	Cv							
VB-9213-0-4-P	2-Way FNPT Composition Disc	1	1/2"	0.4	250	250					
		2		1.3							
		3		2.2							
		4		3.6							
		5	3/4"	5							
		6		6.2							
		7	1"	8.2					150		
		8		11							
		9	1-1/4"	16						90	200
		10	1-1/2"	25						65	140
		11	2"	40						35	80
VB-9253-0-4-P	2-Way FNPT Stainless Trim Teflon Disc	1	1/2"	0.4	250	250					
		2		1.3							
		3		2.2							
		4		3.6							
		5	3/4"	5							
		6		6.2							
		7	1"	8.2					150		
		8		11							
		9	1-1/4"	16						90	200
		10	1-1/2"	25						65	140
		11	2"	40						35	80
VB-9273-0-4-P	2-Way FNPT Stainless Trim No Disc	1	1/2"	0.4	250	250					
		2		1.3							
		3		2.2							
		4		3.6							
		5	3/4"	5							
		6		6.2							
		7	1"	8.2					150		
		8		11							
		9	1-1/4"	16						90	200
		10	1-1/2"	25						65	140
		11	2"	40						35	80
VB-9313-0-4-P	3-Way Mixing FNPT	2	1/2"	2	250	250					
		4		4							
		6	3/4"	6.8						200	
		8	1"	12						140	
		9	1-1/4"	16						95	190
		10	1-1/2"	33						33	75
		11	2"	55							
VB-9323-0-4-P	3-Way Diverting FNPT	4	1/2"	6	250	250					
		6	3/4"	8							
		8	1"	12							
		9	1-1/4"	16							
		10	1-1/2"	30							
		11	2"	42							

^a kPa = psi x 6.895

ASSEMBLY PROCEDURE

The following **bold italic** headings are instructions for step one. Select the specific AV-3XX instructions for the proper valve size. After the mounting bracket is attached, proceed to step 2. See page 8.

Note: Position the bracket on the valve in such a way as to make it convenient to wire the actuator.

AV-391 or AV-393 Valve Linkage for 1/2" to 2" VB-7XXX and Obsolete 1/2" to 1-1/4" VB-9XXX Valve Bodies

1. Mount the bracket on the valve body by screwing the mounting nut into the mounting bracket. Tighten the hex mounting nut, using a 1-5/8" open-ended wrench with a maximum thickness of 3/16" (TOOL-37). See Figure-1.

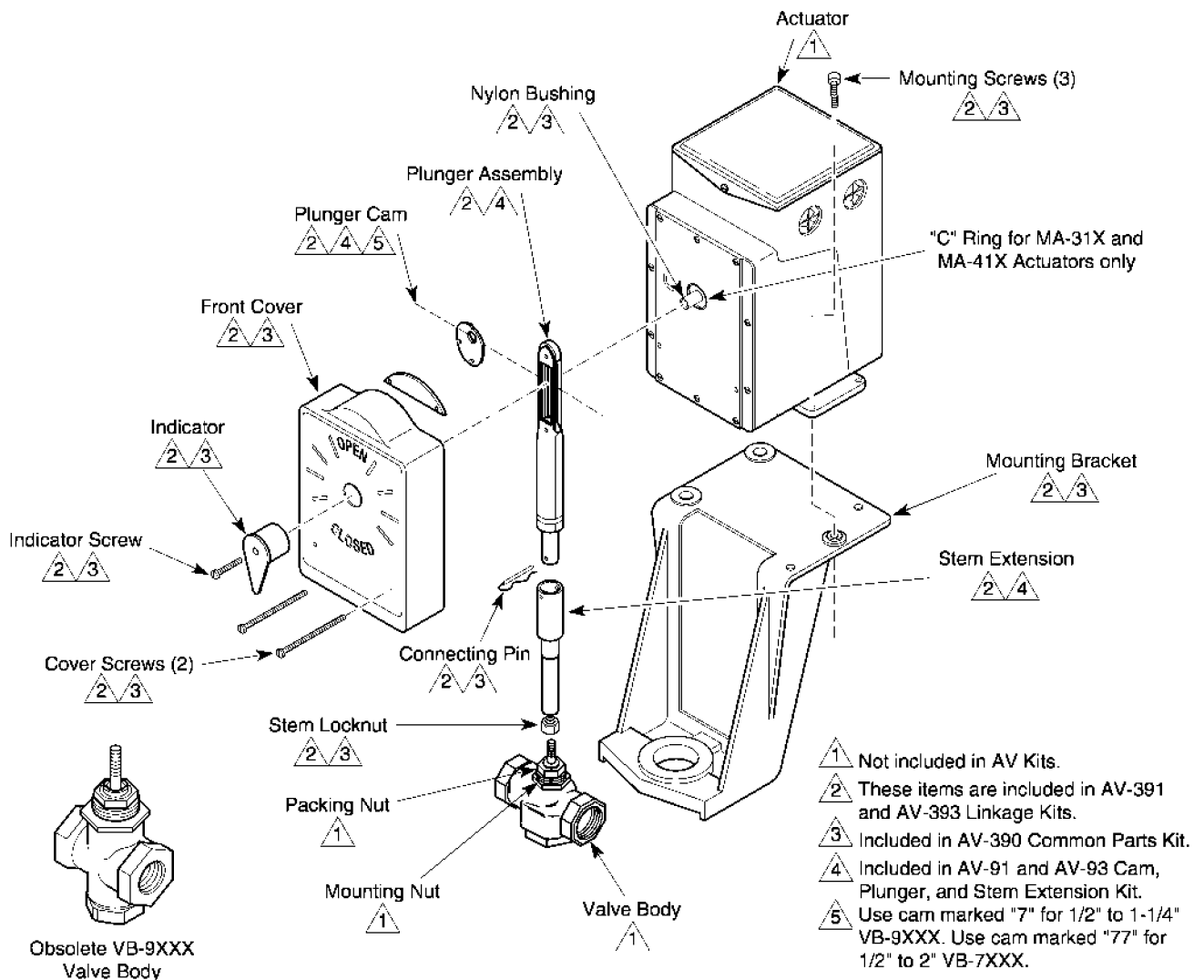

Figure-1 Valve Linkages for 1/2" to 2" VB-7XXX and Obsolete 1/2" to 1-1/4" VB-9XXX Valve Bodies.

AV-392 or AV-394 Valve Linkage for Obsolete 1-1/2" to 2" VB-9XXX Valve Bodies

1. Mount the bracket onto the valve body as follows:
 - a. For Style A VB-9XXX valve bodies, mount the bracket on the valve body by screwing the mounting nut into the mounting bracket. Tighten the hex mounting nut, using a 1-5/8" open-ended wrench with a maximum thickness of 3/16" (TOOL-37). See Figure-1.
 - b. For Style B VB-9XXX valve bodies, mount the bracket onto the valve body by removing the bracket nut, placing the bracket on the valve body, and replacing and tightening the valve bracket nut. See Figure-2.

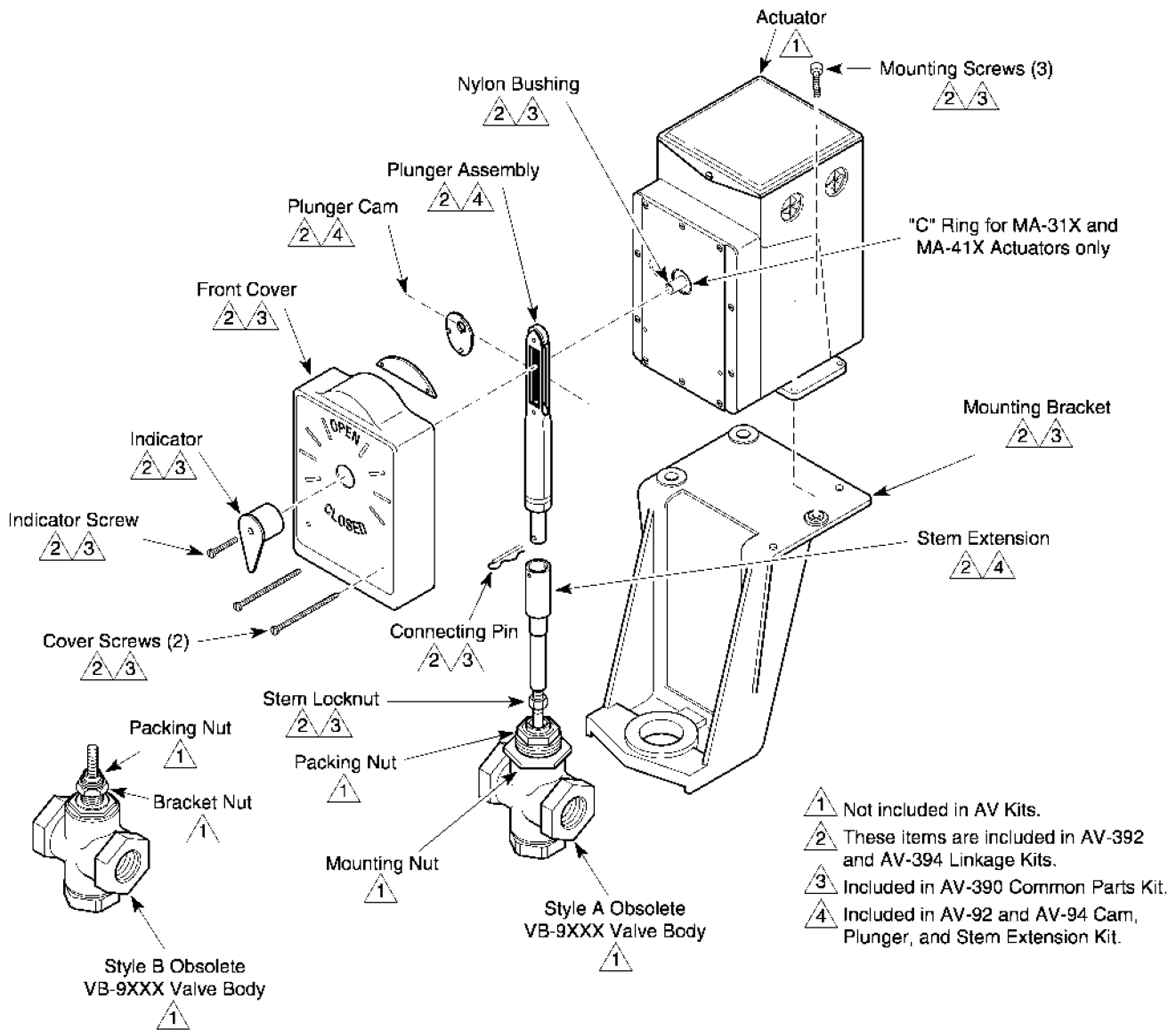

Figure-2 Valve Linkages for Obsolete 1-1/2" to 2" VB-9XXX Valve Bodies.

AV-395 or AV-396 on Current 2-1/2" to 4" VB-9X1X Valve Bodies

1. Mount the bracket onto the valve body by removing the bracket nut, placing the bracket on the valve body, and replacing and tightening the valve bracket nut. See Figure-3.

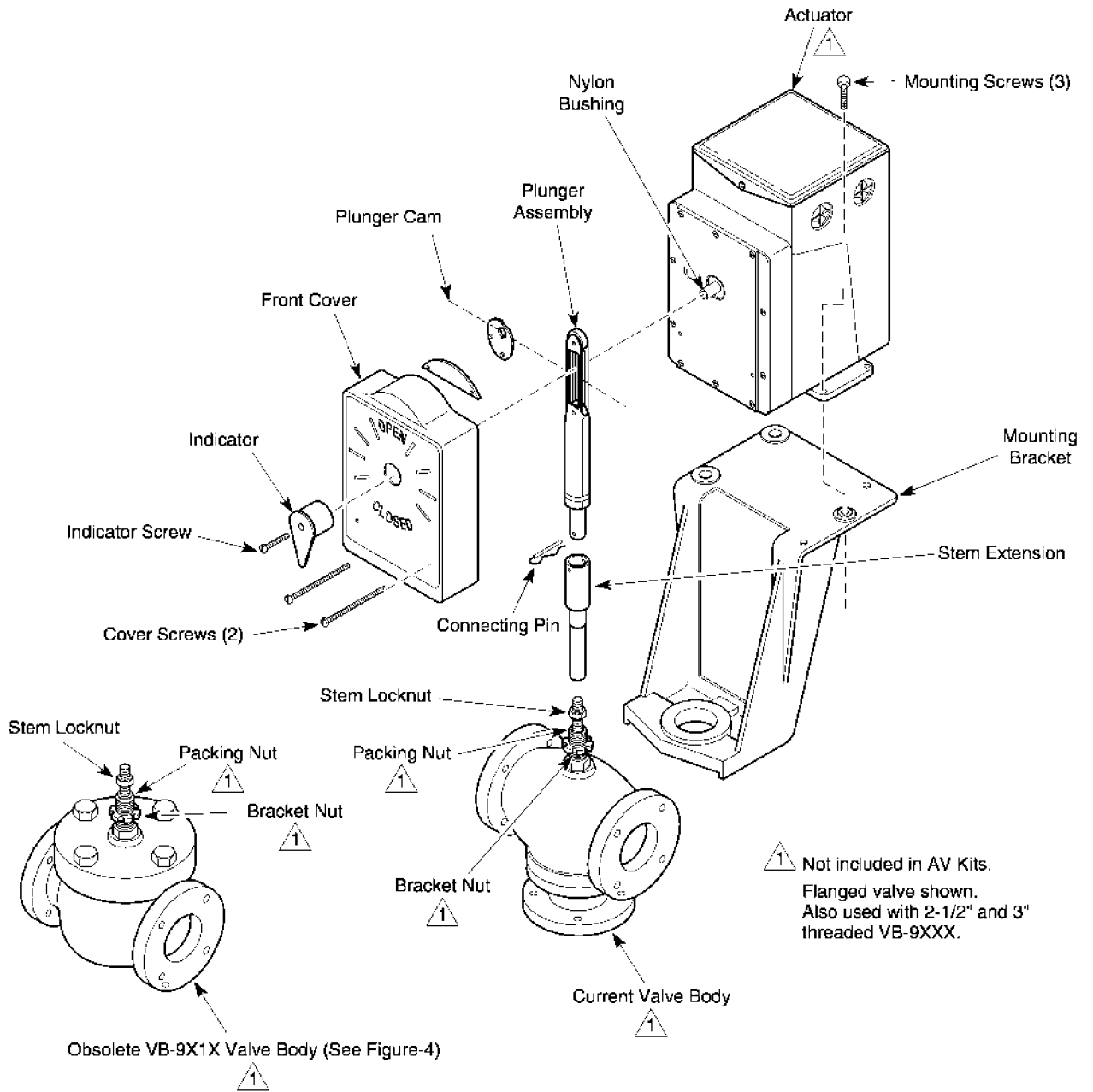
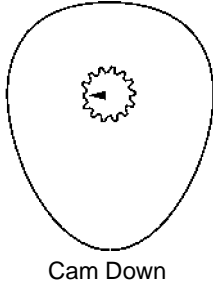
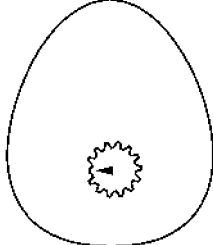
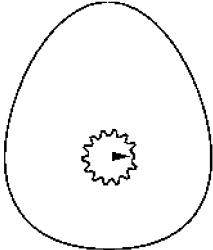
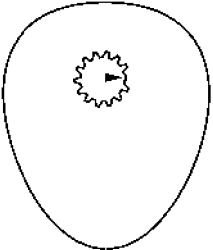

Figure-3 Valve Linkages for Current 2-1/2" to 4" VB-9X1X Valve Bodies.

Table-5 Actuator Shaft and Cam Position.

Actuator Shaft Position	Standard Factory Positions of Cam except for Normally Closed Valves w/MA-3XX and MA-4XX Actuators	Optional Cam Position Used to Reverse Control Action (Standard for Normally Closed Valves w/MA-3XX and MA-4XX)
CW Short tooth on actuator shaft at 9:00	 Cam Down	 Cam Up
CCW Short tooth on actuator shaft at 3:00	 Cam Up	 Cam Down

- Place the plunger cam in the plunger and slip the plunger cam onto the actuator shaft with the cam pointing down. Consult Table-6 for the proper cam.

Table-6 Cam Selection.

Use Cam Marked	Included in Linkage Kits	For These Valve Bodies	With Nominal Stroke
"7"	AV-91, AV-391, AV-93, AV-393	1/2" to 1-1/4" Obs. VB-9XXX	1/2"
"77"		1/2" to 2" VB-7XXX	
"44-2"	AV-92, AV-392, AV-394, AV-395, AV-396	2-1/2" to 4" VB-9XXX 1-1/2" & 2" Obs. VB-9XXX	1"

- Push the valve stem completely down against the lower valve seat.
- Screw the stem extension until the holes in the stem extension and plunger line up.
- Turn the stem extension upward, counterclockwise, into the plunger 2 full turns for 1/2" to 2" valves and 1-1/2 turns for 2-1/2" to 4" valves.
- Raise the actuator up until the connecting pin can be inserted through the holes in the plunger and stem extension.
- Tighten the actuator mounting screws.
- Tighten the lock nut against the stem extension.
- Place the front cover over the plunger assembly and fasten it to the actuator with two self-tapping screws.
- Install the position indicator to the end of the actuator shaft, pointing to "Closed".

CHECKOUT

1. Drive the actuator so that the valve stem is fully up. If the valve is a three-way, check for plunger compression. See Figure-6.
2. Drive the actuator so that the valve stem is fully down. Check for plunger compression. See Figure-7.

Note: Check the plunger spring compression, refer to Figure-6 and Figure-7. The length of the stem extension should be adjusted so that the valve disc seats before the actuator reaches the end of the closing stroke. The balance of the actuator stroke is taken up in the plunger spring compression, which should be approximately 1/16" (1.6 mm). This provides pressure on the disc in the closed position(s) and also compensates for disc and seat wear. On three-way valves, spring compression must be provided on both upper and lower seats.

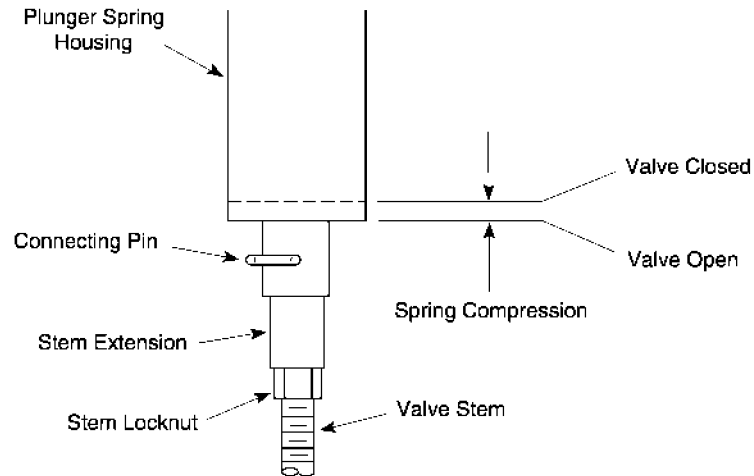

Figure-6 Valve Compression Stem Up.

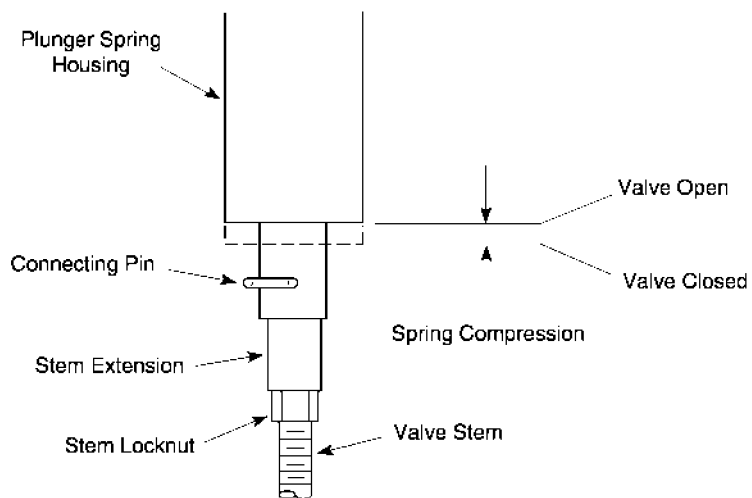

Figure-7 Valve Compression Stem Down.

MAINTENANCE

Regular maintenance of the total system is recommended to assure sustained optimum performance.

DIMENSIONAL DATA

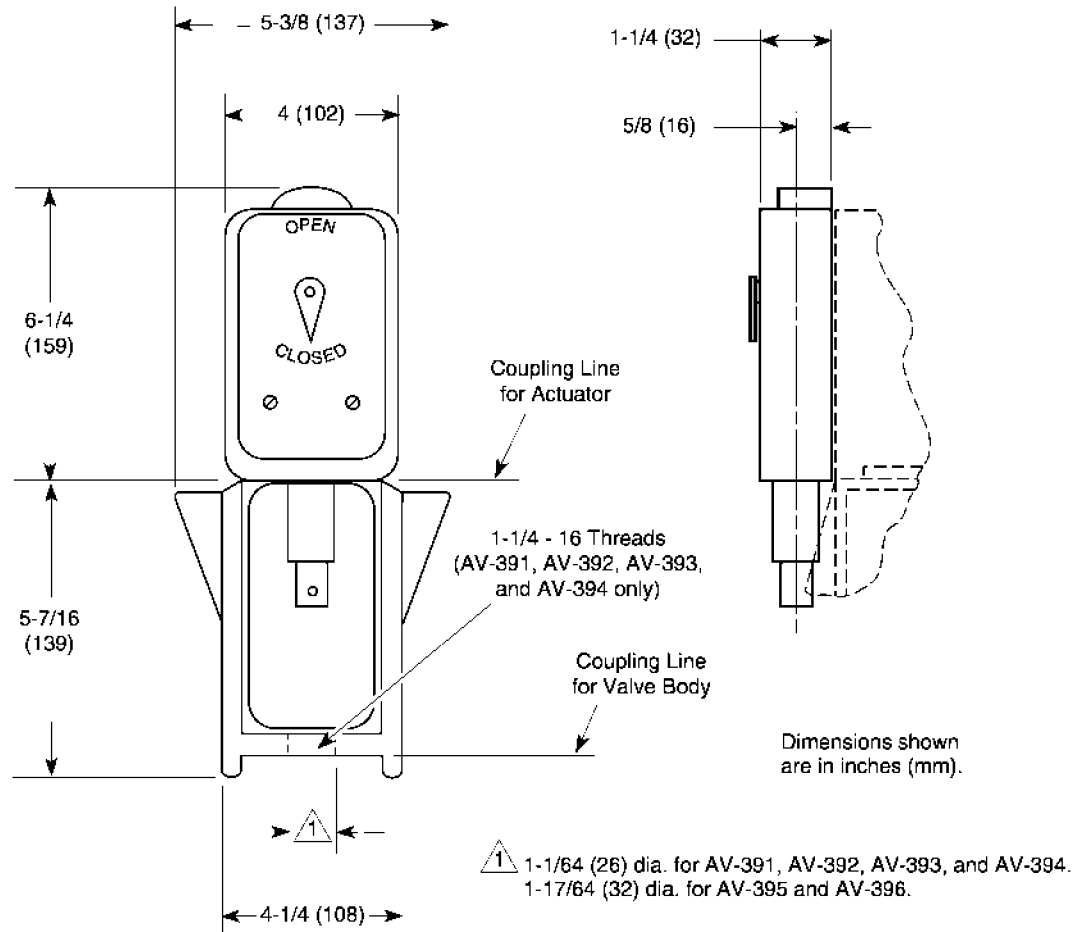

Figure-8 Dimensions of AV-391, AV-392, AV-393, AV-394, AV-395, and AV-396.

On October 1st, 2009, TAC became the Buildings business of its parent company Schneider Electric. This document reflects the visual identity of Schneider Electric, however there remains references to TAC as a corporate brand in the body copy. As each document is updated, the body copy will be changed to reflect appropriate corporate brand changes.

Copyright 2010, Schneider Electric
All brand names, trademarks and registered
trademarks are the property of their respective
owners. Information contained within this
document is subject to change without notice.

F-24376-9

